

# Differential pressure switch Ex protection EEx-d, IP 65, for low pressure ranges Model DA10



WIKA data sheet PV 35.45



## Applications

- Differential pressure monitoring and direct switching of electrical loads
- For gaseous and liquid, aggressive and highly viscous or contaminated media, also in aggressive ambience
- Process industry: Chemical/petrochemical, on- and offshore, technical gases, environmental technology, machine building and general plant construction, water treatment, pharmaceutical industry
- Pump monitoring and control / filter monitoring, level measurement in closed tanks
- Ignition protection type GAS Ex-d DUST Ex-tD Gr. II Cat. 1/2 GD

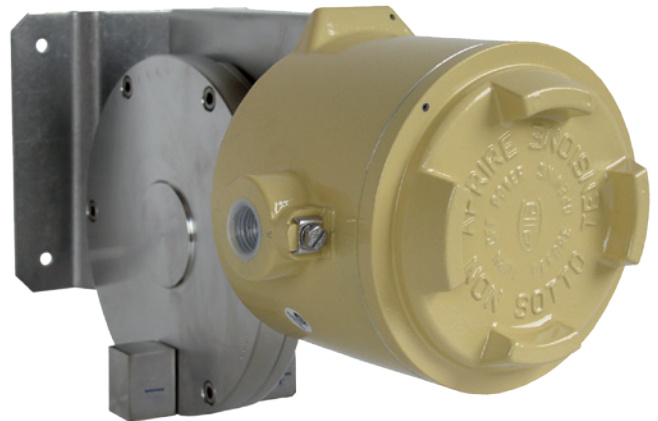

Differential pressure switch model DA10

## Special features

- Case flameproof enclosure
- Ingress protection IP 65, NEMA 4
- Ambient temperature -30 ... +85 °C
- 1 or 2 independent switch points, high contact rating up to 15 A / AC 220 V
- Differential pressure from 16 mbar, working pressure (static pressure) up to 10 bar

## Description

These high-quality differential pressure switches have been developed especially for safety-critical applications. High quality and product manufacturing to ISO 9001:2000 ensures reliable monitoring of your plant. In production, the switches are traced by quality assurance software at every step and subsequently are 100 % tested.

All wetted parts materials are from stainless steel as standard. Each switch family is available in IP 65, Ex-ia or Ex-d versions (Ex-ia see model DW10, data sheet PV 35.44).

In order to ensure as flexible operation as possible, the pressure switches are equipped with micro switches, which make it possible to switch an electrical load of up to 15 A / AC 220 V directly. For smaller contact ratings, such as for PLC applications, Argon gas-filled micro switches with gold-plated contacts can be selected as an option. By using a diaphragm measuring cell with fulcrum lever transmission, the model DA10 pressure switch is extremely robust and guarantees optimal operating characteristics.

## Standard version

### Case

Aluminium, epoxy resin coated,  
case cover with screw-type cover, due to anti-twist device  
secured against unauthorised intervention

### Ingress protection

IP 65 per EN 60529 / IEC 529

### Permissible temperature

Ambient: -30 ... +85 °C

### Process connection

Stainless steel, lower mount (LM)  
2 x ¼ NPT (female)

### Measuring system

Diaphragm measuring cell with fulcrum lever transmission

### Wetted parts

Process connection: Stainless steel 304  
Diaphragm: Stainless steel 316  
Sealing: NBR

### Max. working pressure (static pressure)

Either side  
max. 10 bar Code: 10

### Setting ranges, max. switch hysteresis

Setting range	Max. switch hysteresis		
	1 switch contact	2 switch contacts	1 switch contact with settable hysteresis
0 ... 16 mbar	1.2 mbar	1.6 mbar	- ... -
0 ... 25 mbar	1.2 mbar	1.6 mbar	3 ... 8 mbar
0 ... 40 mbar	1.6 mbar	2.2 mbar	4 ... 11 mbar
0 ... 60 mbar	2.0 mbar	2.5 mbar	5 ... 14 mbar

### Switch contacts

one or two SPDT (change-over) micro switches selectable,  
DPDT function through two SPDT micro switches with simultaneous triggering within 0.5 % of span, in the following variants:

Code	Switch
U	1 x SPDT
D	2 x SPDT

Code	Design	Electrical rating (resistive load) <sup>2)</sup>	
		AC	DC
<b>Fixed switch hysteresis</b>			
1	<b>Silver contacts</b>	<u>15 A, 220 V</u>	<u>2 A, 24 V</u> 0.5 A, 125 V 0.25 A, 220 V
2	<b>Gold-plated contacts</b>	<u>1 A, 125 V</u>	<u>0.5 A, 24 V</u>
3	<b>Silver contacts</b> inert gas filled Tamb: -30 ... +70 °C	<u>15 A, 220 V</u>	<u>2 A, 24 V</u> 0.5 A, 220 V
4	<b>Gold-plated contacts</b> inert gas filled Tamb: -30 ... +70 °C	<u>1 A, 125 V</u>	<u>0.5 A, 24 V</u>
<b>Adjustable switch hysteresis</b>			
5	<b>Silver contacts <sup>1)</sup></b>	<u>20 A, 220 V</u>	<u>2 A, 24 V</u> 0.5 A, 220 V

1) Max. 1 switch contact

2) Only the underlined data are shown on the product label

### Repeatability

≤ 1 % of span

### Note

If the switch point is below 10 % of the span, the pressure switch should be mounted vibration-free in order to avoid any accidental switching.

## Switch points

The switch points can be set to your requirements, free-of-charge.

Please specify:

Switch point, switching direction for each contact (e.g. switch point 1: 0.5 bar, falling, switch point 2: 3 bar, rising)

With two micro switches, the switch points can be set independently of each other.

After unscrewing the case cover, **switch point adjustment** can be made using the adjustment screw. The switch point is settable within the entire measuring range with the **following general rule:**

- Define the value  $A = 2 \times \text{repeatability} + \text{switch hysteresis}$
- If the pressure is rising, the switch point should be set between (min. + value A) up to max. of the setting range
- If the pressure is falling, the switch point should be set between min. up to (max. - value A) of the setting range

### Example:

Setting range: 0 ... 1 bar with one switch contact

Repeatability: 1 % of 1 bar = 10 mbar

Switch hysteresis = 15 mbar (see table setting ranges)

Value  $A = 2 \times 10 \text{ mbar} + 15 \text{ mbar} = 35 \text{ mbar}$

If the pressure is rising, the switch point should be set between 35 mbar up to 1 bar.

If the pressure is falling, the switch point should be set between 0 up to 965 mbar.

For optimal performance we suggest the switch point lies between 25 % and 75 % of the setting range.

## Electrical connection

1/2 NPT female, cable connection using internal terminal block, protective conductor connection using internal and external screw, max. earth cable cross-section 4 mm<sup>2</sup>

### Pressure switch certified per:

- Pressure equipment directive 97/23/EC (PED, annex 1, category IV, safety accessories, module B + D)
- Low voltage directive 73/23 EEC and 93/68 EEC

## Dielectric strength

Safety class I (EN 61298-2: 1997-06)

## Mounting

Direct or wall mounting

Preferred connection location of the process connection should be below.

## Weight

approx. 10 kg

## Options

- Other process connection, also with adapter
- Electrical connection 3/4 NPT, G 1/2, G 3/4 or M20 x 1.5 (female)
- Cable gland on request
- 2" pipe-mounting kit (with clamping element)
- Version for off-shore <sup>3)</sup> or tropicalised application <sup>3)</sup>
- Accessories:
  - Three-way or five-way valve

<sup>3)</sup> Inert gas filled contacts required

## Approvals and certificates

- GOST-R certificate
- Test certificate \*CA\* (confirmation of the switching accuracy)
- Test report \*CP\* (3-time listing of the switch point, requires switch point specification)
- Material certificate 3.1 per EN 10204

## Dimensions in mm

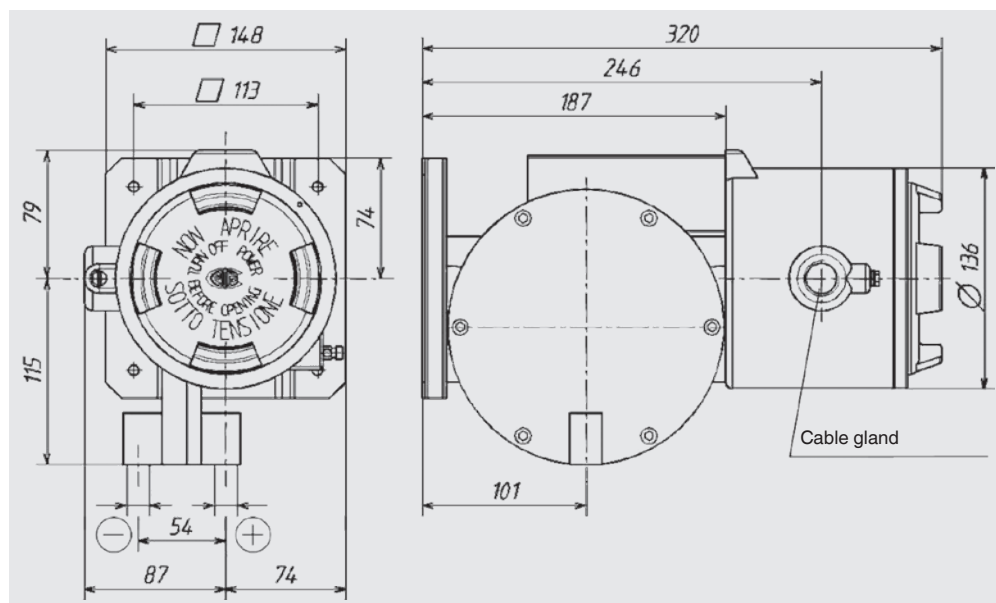

### Ordering information

Model / Switch contacts with version / Setting range / 2 x Process connection / Electrical connection / Switch point(s) / Switching direction(s) / Options

Example: DA10 - U1 - 0/16 mbar - 2 x 1/4" NPT-F - 1/2" NPT-F

© 2011 WIKA Alexander Wiegand SE & Co. KG, all rights reserved.  
The specifications given in this document represent the state of engineering at the time of publishing.  
We reserve the right to make modifications to the specifications and materials.



**WIKAI**  
**WIKAI Alexander Wiegand SE & Co. KG**  
Alexander-Wiegand-Straße 30  
63911 Klingenberg/Germany  
Tel. (+49) 9372/132-0  
Fax (+49) 9372/132-406  
E-mail info@wika.de  
www.wika.de