

Compact differential pressure switch IP 65, for high working pressures PN 250 Model DCA



WIKA data sheet PV 35.46



Applications

- Differential pressure monitoring and direct switching of electrical loads
- For gaseous and liquid, aggressive and highly viscous or contaminated media, also in aggressive ambience
- Process industry: Chemical/petrochemical, on- and offshore, technical gases, environmental technology, machine building and general plant construction, water treatment, pharmaceutical industry
- Pump monitoring and control / filter monitoring, level measurement in closed tanks

Special features

- Ingress protection IP 65, NEMA 4
- Ambient temperature -30 ... +85 °C
- 1 switch point, SPDT or DPDT with a high contact rating of up to 15 A / AC 220 V
- Working pressure (static pressure) up to 250 bar



Compact differential pressure switch model DCA

Description

These high-quality differential pressure switches have been developed especially for safety-critical applications. The high quality of the products ensures reliable monitoring of your plant. The manufacturer Cella is certified to ISO 9001. In production, the switches are traced by quality assurance software at every step and subsequently are 100 % tested. All wetted parts materials are from stainless steel. Each switch family is available in IP 65, Ex-ia or Ex-d versions.

In order to ensure as flexible operation as possible, the pressure switches are equipped with micro switches, which make it possible to switch an electrical load of up to 15 A / AC 220 V directly. For smaller contact ratings, such as for PLC applications, Argon gas-filled micro switches with gold-plated contacts can be selected as an option. A DPDT switch is realised through 2 SPDT switches, which switch simultaneously within 2 % of the full scale value.

By using a liquid-filled diaphragm measuring cell with fulcrum lever transmission, the model DCA pressure switch is extremely reliable and guarantees optimal operating characteristics.

Standard version

Case

Aluminium, epoxy resin coated,
case cover with screw-type cover, due to anti-twist device
secured against unauthorised intervention

Ingress protection

IP 65 per EN 60529 / IEC 529

Permissible temperature

Ambient: -30 ... +85 °C

Process connection

Stainless steel, lower mount (LM)
2 x ¼ NPT (female)

Measuring system

Double liquid-filled diaphragm measuring cell with fulcrum
lever transmission

Wetted parts

Process connection: Stainless steel 316
Diaphragm element: See table setting ranges ...
Sealing: NBR

Max. working pressure (static pressure)

Either side
max. 250 bar

Switch contacts

Code	Type	Version	Electrical rating (resistive load) ²⁾	
			AC	DC
1	SPDT	Silver contacts	<u>15 A, 220 V</u>	2 A, 24 V <u>0.5 A, 125 V</u> <u>0.25 A, 220 V</u>
2 ¹⁾	DPDT	Silver contacts	<u>5 A, 220 V</u>	<u>0.5 A, 24 V</u>
3	SPDT	Silver contacts inert gas filled T _{amb} : -30 ... +70 °C	<u>15 A, 220 V</u>	2 A, 24 V <u>0.5 A, 220 V</u>
5	SPDT	Gold-plated contacts inert gas filled T _{amb} : -30 ... +70 °C	<u>1 A, 220 V</u>	<u>0.5 A, 24 V</u>

1) Simultaneous triggering within 2 % of span

2) Only the underlined data are shown on the product label

Repeatability

≤ 1 % of span

Note

If the switch point is below 10 % of the span, the pressure
switch should be mounted vibration-free in order to avoid any
accidental switching.

Setting ranges, material of diaphragm element, max. switch hysteresis

Setting range	Material of diaphragm element	Max. switch hysteresis	
		SPDT	DPDT
0 ... 2.5 bar	Stainless steel 316	80 mbar	130 mbar
0 ... 4 bar	Stainless steel 304	120 mbar	200 mbar
0 ... 6 bar	Stainless steel 304	120 mbar	200 mbar
0 ... 10 bar	Stainless steel 304	210 mbar	280 mbar

Switch points

The switch points can be set to your requirements, free-of-charge.

Please specify:

Switch point, switching direction (e.g. switch point: 0.5 bar, falling)

After unscrewing the case cover, **switch point adjustment** can be made using the adjustment screw. The switch point is settable within the entire measuring range with **the following general rule:**

- Define the value $A = 2 \times \text{repeatability} + \text{switch hysteresis}$
- If the pressure is rising, the switch point should be set between (min. + value A) up to max. of the setting range
- If the pressure is falling, the switch point should be set between min. up to (max. - value A) of the setting range

Example:

Setting range: 0 ... 1 bar with one switch contact

Repeatability: 1 % of 1 bar = 10 mbar

Switch hysteresis = 15 mbar (see table setting ranges)

Value $A = 2 \times 10 \text{ mbar} + 15 \text{ mbar} = 35 \text{ mbar}$

If the pressure is rising, the switch point should be set between 35 mbar up to 1 bar.

If the pressure is falling, the switch point should be set between 0 up to 965 mbar.

For optimal performance we suggest the switch point lies between 25 % and 75 % of the setting range.

Electrical connection

1/2 NPT female, cable connection using internal terminal block, protective conductor connection using internal and external screw, max. earth cable cross-section 4 mm²

Pressure switch certified per:

- Pressure equipment directive 97/23/EC (PED, annex 1, category IV, safety accessories, module B + D)
- Low voltage directive 73/23 EEC and 93/68 EEC

Dielectric strength

Safety class I (EN 61298-2: 1997-06)

Mounting

Direct or wall mounting

Preferred connection location of the process connection should be below.

Weight

approx. 5.4 kg

Options

- Other process connection, also with adapter
- Case from stainless steel 316
- Electrical connection 3/4 NPT, G 1/2 or M20 x 1.5 (female)
- Cable gland on request
- 2" pipe-mounting kit (with clamping element)
- Version for off-shore ³⁾ or tropicalised application ³⁾
- Version for applications to NACE ³⁾
- Version for ammonia applications ³⁾
- Oil and grease free version for oxygen applications
- Wetted parts made of Monel
- Version to
GAS Ex-ia IIC T6 and T4 - Dust Ex-iaD A20 IP65 T85 and T135 ³⁾

Electrical characteristics: $U_i = 30 \text{ V}$

$I_i = 100 \text{ mA}$

$P_i = 0.75 \text{ W}$

$C_i = 0 \text{ }\mu\text{F}$

$L_i = 0 \text{ mH}$

- Accessories:
- Three-way or five-way valve

³⁾ Inert gas filled contacts required

Approvals and certificates

- SIL 2 version ³⁾
- GOST-R certificate
- Test certificate *CA* (confirmation of the switching accuracy)
- Test report *CP* (3-time listing of the switch point, requires switch point specification)
- Material certificate 3.1 per EN 10204

Dimensions in mm

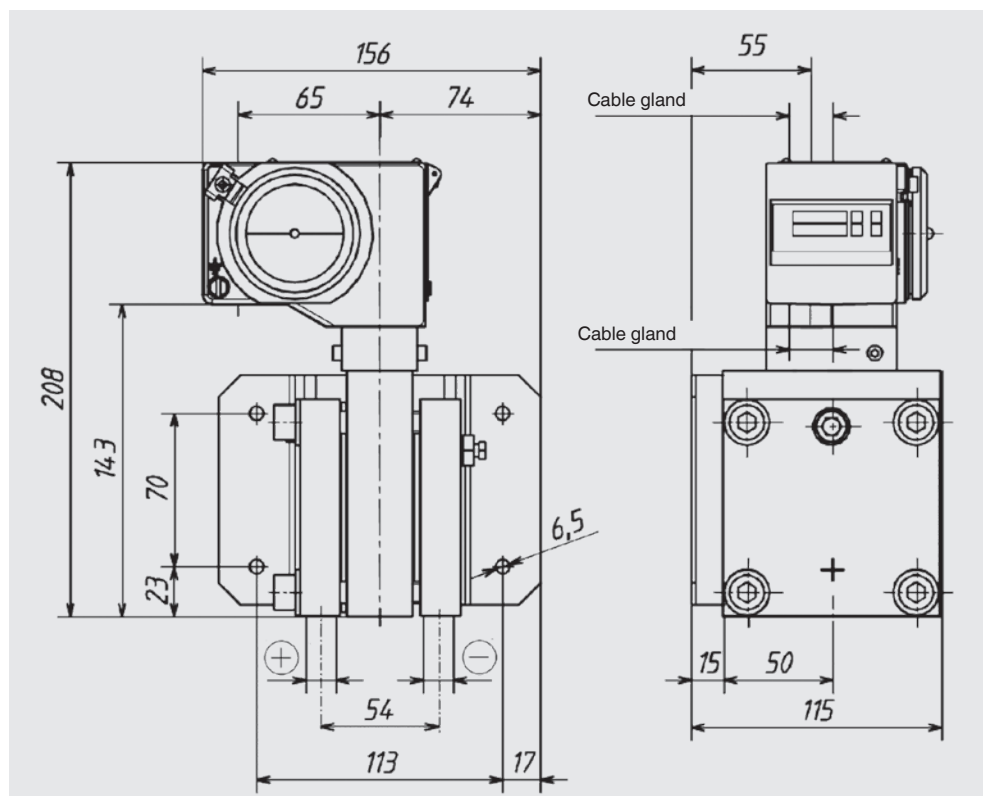

Ordering information

Model / Max. working pressure (static pressure) / Sensor code / 2 / Switch contact with version / Setting range / 2 x process connection / 2 x electrical connection / Switch point / Switching direction / Options

Example: DCA - H - 2 - 1 - 0/6 bar - 2 x 1/4" NPT-F - 2 x 1/2" NPT-F

© 2011 WIKA Alexander Wiegand SE & Co. KG, all rights reserved.
The specifications given in this document represent the state of engineering at the time of publishing.
We reserve the right to make modifications to the specifications and materials.

