

Gas actuated combi-thermometer with Pt100 electrical output signal Model 76, stainless steel version

WIKA data sheet TV 17.01

Applications

- Control and regulation of industrial processes
- Monitoring of plants and switching of electric circuits
- Universally suitable for machine building, plant, vessel, apparatus construction and food industry

Special features

- Instruments meet the highest standards of measurement technology
- Housing and sheath from stainless steel
- Two independent measuring systems in one instrument
- Various connection designs possible

Description

This series of thermometers is designed for installation in pipes, vessels, plant and machinery. The gas actuated thermometer enables the local visualisation of measured values, while, in addition, the integrated Pt100 resistance sensor provides an electrical output signal for further processing.

The gas actuated combi-thermometer with capillary is intended for bridging longer distances and, with its flexible capillary, this version can be used in locations which are not easily accessible.

Optional electrical switch contacts

The model 76 gas actuated thermometer can be delivered with integrated switch contacts.

For switch contacts, sliding and magnetic snap-action contacts, inductive contacts or electronic contacts for PLC switching are available.



Gas actuated thermometer model R76.100, design 1
Fig. left: with electrical output signal and switch contact
Fig. right: with electrical output signal

The set pointer can be adjusted via the window using a removable adjustment key (mounted on the terminal box).

For further information on the different switch contacts please see data sheet AC 08.01.

Optional temperature transmitter

A temperature transmitter, with a 4 ... 20 mA or 0 ... 10 V (machine building) output signal, programmable via software, can be mounted into the model 76 gas actuated thermometer. Thus the measured temperature values can be transmitted safely and simply.

Notes on the WIKA transmitter program, see page 3.

Standard version

Measuring principle

mechanical: inert gas expansion system, non-toxic

electrical: Pt100, 3-wire connection (DIN IEC 751)

Nominal size in mm

100, 160

Connection type

S Standard (male thread connection)

1 Plain stem (without thread)

2 Male nut

3 Union nut (female)

4 Compression fitting (sliding on stem)

5 Union nut with fitting

6.3 Compression fitting (sliding on spiral protection hose)

Instrument version

Model	NS	Version
R76.100	100	lower mount
R76.160	160	
F76.100	100	lower mount, with capillary and surface mounting bracket
F76.160	160	

Accuracy class

mechanical: Class 1 per DIN EN 13190

with switch contact: class 1 per DIN 16196

electrical: Class B per DIN IEC 751

Working pressure

Normal (1 year): Measuring range per DIN EN 13190

Short time (24 h max.): Scale range per DIN EN 13190

Rated operating ranges and conditions

per DIN EN 13190

Case, bezel ring, stem, process connection

Stainless steel 1.4571

Dial

Aluminium, white, black lettering

Window

Laminated safety glass

Pointer

Aluminium, black, micro adjustment

Capillary (connection design 6.3)

Ø 2 mm, stainless steel 1.4571, bending radius no less than 6 mm

Spiral protection hose Ø 7 mm, flexible

Length to user specifications

Temperature limits for storage and transport

-50 ... +70 °C (DIN EN 13190) without liquid damping

-20 ... +60 °C (DIN EN 13190) with liquid damping

Electrical connection

Junction box

Permissible ambient temperature at case

0 ... +40 °C max. (others on request)

Permissible pressure rating of stem

25 bar max., static

Ingress protection

IP 65 per EN 60529 / IEC 529

Scale, measuring ranges 1), error limits

(DIN EN 13190 or DIN 16196)

Scale graduation per WIKA standard

Scale range in °C	Measuring range in °C	Scale spacing in °C	Error limit ± °C	
			DIN EN 13190	DIN 16196
-80 ... +60	-60 ... +40	2	2.0	3.00
-60 ... +40	-50 ... +30	1	1.0	1.50
-40 ... +60	-30 ... +50	1	1.0	1.50
-30 ... +50	-20 ... +40	1	1.0	1.50
-20 ... +60	-10 ... +50	1	1.0	1.50
-20 ... +80	-10 ... +70	1	1.0	1.50
0 ... 60	+10 ... +50	1	1.0	1.50
0 ... 80	+10 ... +70	1	1.0	1.50
0 ... 100	+10 ... +90	2	1.0	1.50
0 ... 120	+10 ... +110	2	2.0	3.00
0 ... 160	+20 ... +140	2	2.0	3.00
0 ... 200	+20 ... +180	2	2.0	3.00
0 ... 250	+30 ... +220	5	2.5	3.75
0 ... 300	+30 ... +270	5	5.0	7.50

1) The measuring range is indicated on the dial by two triangular marks.

Only within this range is the stated error limit valid in accordance with DIN EN 13190 or DIN 16196 (with switch contact).

Options

- Scale range °F, °C/°F (dual scale)
- Case with liquid damping
- Case with food-compatible liquid damping
- Pt100 class A
- Radial connection other than lower
- Window of clear plastic
- Special measuring ranges or dial printing to customer specifications (on request)
- Switch contacts (data sheet AC 08.01)
- Analogue or digital temperature transmitters from WIKA transmitter range

WIKA transmitter range

Model	Description	Data sheet
T19	Analogue temperature transmitter, configurable measuring ranges for Pt100 resistance thermometer	TE 19.03
T24	Analogue temperature transmitter, PC-configurable for Pt100 resistance thermometer	TE 24.01
T32	Digital temperature transmitter, configurable, HART® protocol	TE 32.04
T53	Digital temperature transmitter FOUNDATION™ fieldbus and PROFIBUS® PA	TE 53.01

Dimensions in mm

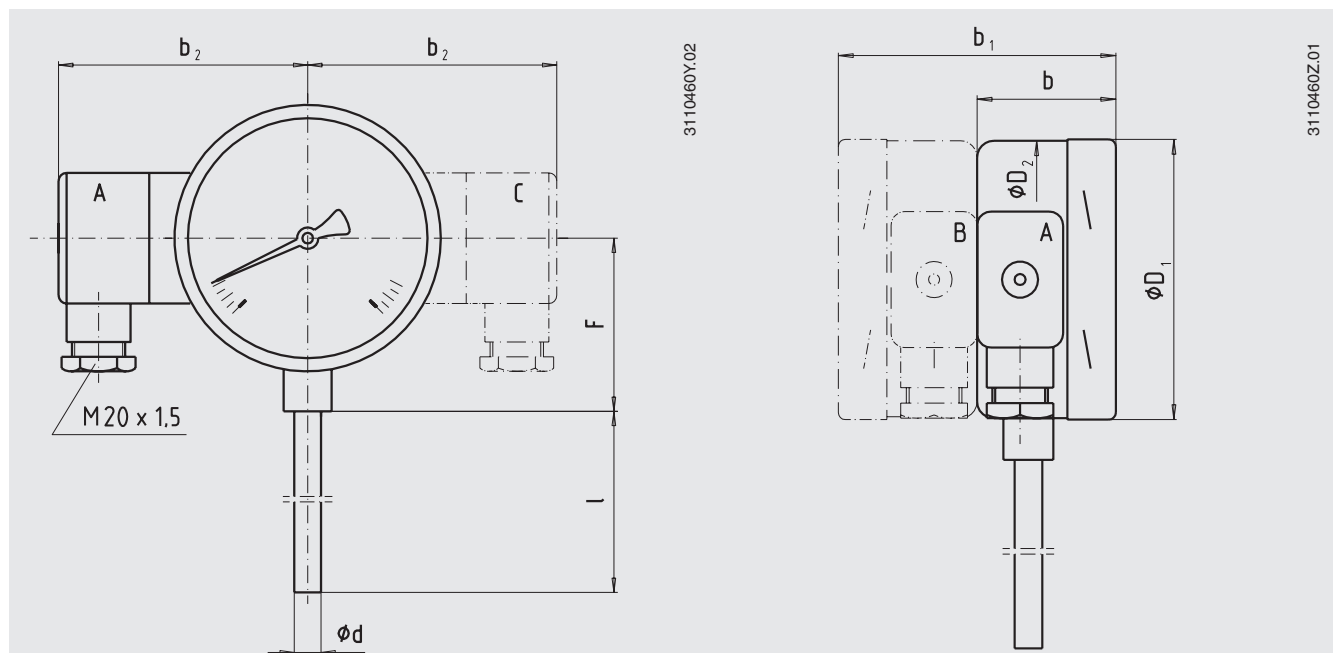

Use of terminal boxes (A, B and C in the above drawing)

- Standard version: A for Pt100
- Transmitter option: B for transmitter
- Switch contact option: A for switch contact and C for Pt100
- Switch contact and transmitter option: A for switch contact and B for transmitter

Nominal size	Dimensions in mm Without transmitter			Dimensions in mm With transmitter			d	D1	D2	F	Weight in kg	
	Switch contact without	1 or 2	3	Switch contact without	1 or 2	3						
NS	b	b	b	b1	b1	b1						
100	50	88	-	100	138	-	92	10	101	99	83	approx. 1.2
160	50	88	96	100	138	146	122	10	161	159	113	approx. 1.4

Designation of terminal connectors

Pt100 with 3-wire connection (standard)

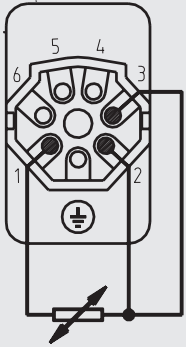

Connection with temperature transmitter (option)

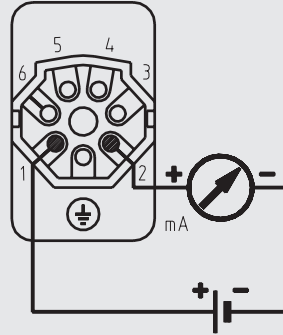

4 ... 20 mA loop
Terminal 1: +
Terminal 2: -

Switch contact (option)

see data sheet AC 08.01

3118495.01

Connection design

Design S, standard (male thread connection)

Standard stem lengths: $l_1 = 200, 210, 310, 410$ mm
(not with F76.xxx)

Nominal size NS	Process connection		Dimensions in mm		
	G	i	SW	d4	$\varnothing d$
100, 160	G 1/2 B	14	27	26	10
	G 3/4 B	16	32	32	10
	1/2 NPT	19	22	-	10
	3/4 NPT	20	30	-	10

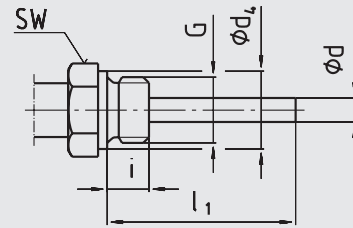

Legend:

- G Male thread
- i Thread length
- $\varnothing d4$ Diameter of the sealing collar
- SW Flats
- $\varnothing d$ Stem diameter

3073050.03(G1)

Design 1, plain stem (without thread)

Standard stem lengths: $l = 200, 210, 250, 310, 400, 500$ mm

Basis for design 4, compression fitting

Nominal size NS	Dimensions in mm	
	d6 ¹⁾	$\varnothing d$
100, 160	18	10

1) Not applicable to version with capillary

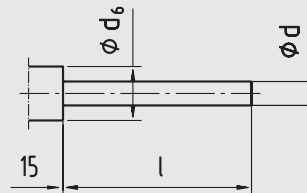

Legend:

- $\varnothing d6$ Plain diameter
- $\varnothing d$ Stem diameter

3073050.03(G1)

Design 2, male nut

Standard stem lengths: $l_1 = 200, 210, 250, 310, 400$ mm

Nominal size NS	Process connection		Dimensions in mm		
	G	i	SW	$\varnothing d$	
100, 160	G 1/2 B	20	27	10	
	M20 x 1.5	15	22	10	

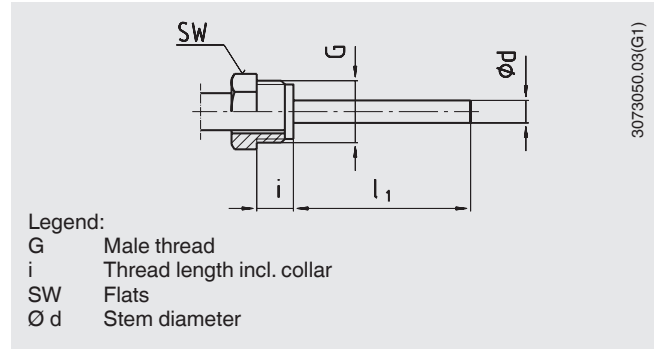

3073050.03(G1)

Design 3, union nut

Standard stem lengths: $l_1 = 200, 210, 250, 310, 400$ mm

Nominal size NS	Process connection		Dimensions in mm		
	G ₁	i	SW	$\varnothing d$	
100, 160	G 1/2	8.5	27	10	
	G 3/4	10.5	32	10	
	M24 x 1.5	13.5	32	10	

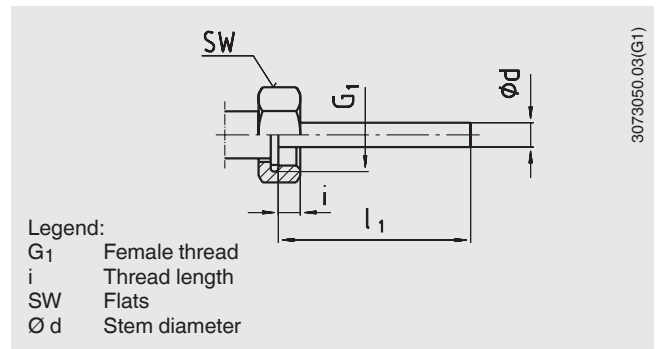

3073050.03(G1)

Design 4, compression fitting (sliding on stem)

Stem length: $l_1 =$ variable

Length $L = l_1 + 40$ mm

Nominal size NS	Process connection		Dimensions in mm			
	G	i	SW	d ₄	$\varnothing d$	
100, 160	G 1/2 B	14	27	26	10	
	G 3/4 B	16	32	32	10	
	1/2 NPT	19	22	-	10	
	3/4 NPT	20	30	-	10	

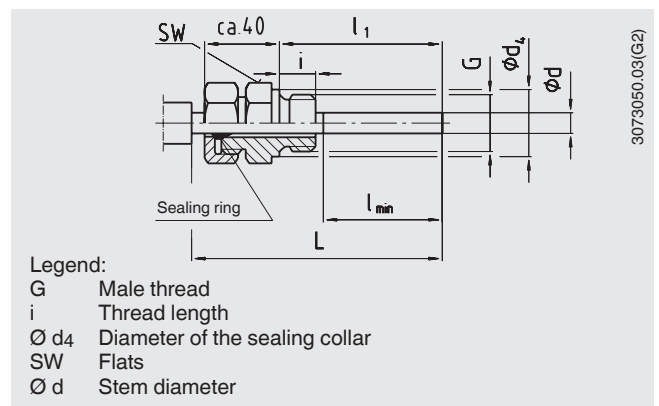

3073050.03(G2)

Design 5, union nut with fitting

Standard stem lengths: $l_1 = 200, 210, 250, 310, 400$ mm

Nominal size NS	Process connection		Dimensions in mm		
	G	i	SW	d4	$\varnothing d$
100, 160	G 1/2 B	14	27	26	10
	G 3/4 B	16	32	32	10
	1/2 NPT	19	22	-	10
	3/4 NPT	20	30	-	10

Option: connection with union nut M24 x 1.5 with fitting
M18 x 1.5

Nominal size NS	Process connection		Dimensions in mm		
	G	i	SW	d4	$\varnothing d$
100, 160	M18 x 1.5	12	32	23	10

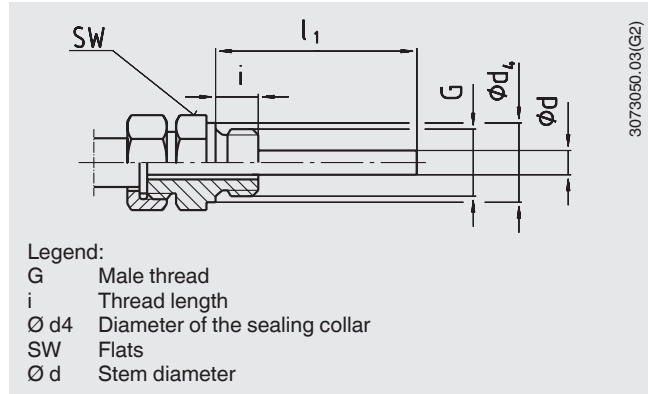

Design 6.3, compression fitting sliding on spiral protection hose (compression fitting is not leak-proof)

Standard stem length: $l_1 = 200$ mm (others on request)

Nominal size NS	Process connection		Dimensions in mm		
	G	i	SW	d4	$\varnothing d$
100, 160	G 1/2 B	14	27	26	10
	G 3/4 B	16	32	32	10
	1/2 NPT	19	22	-	10
	3/4 NPT	20	30	-	10

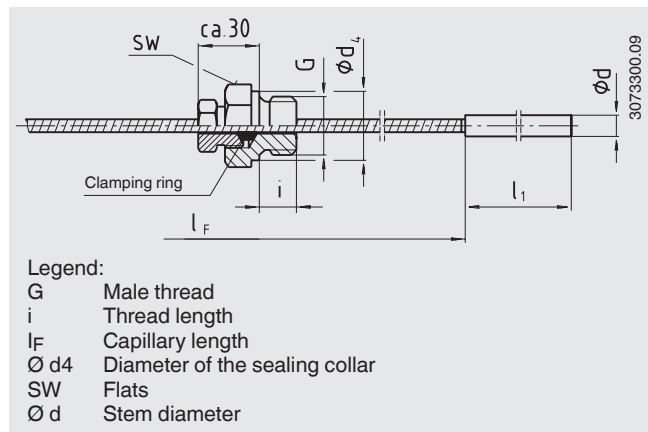

Ordering information

Model / Nominal size / Scale range / Design of connection / Process connection / Length l_1 , l_1 / Capillary length l_F / Options

© 2011 WIKA Alexander Wiegand SE & Co. KG, all rights reserved.
The specifications given in this document represent the state of engineering at the time of publishing.
We reserve the right to make modifications to the specifications and materials.

